

Setting Tree

Every set consists of two numbers
 The zone, and the tempo
 Zones 1-9 Tempo 1-3
 High outside set
 13 Zone = 1, tempo = 3

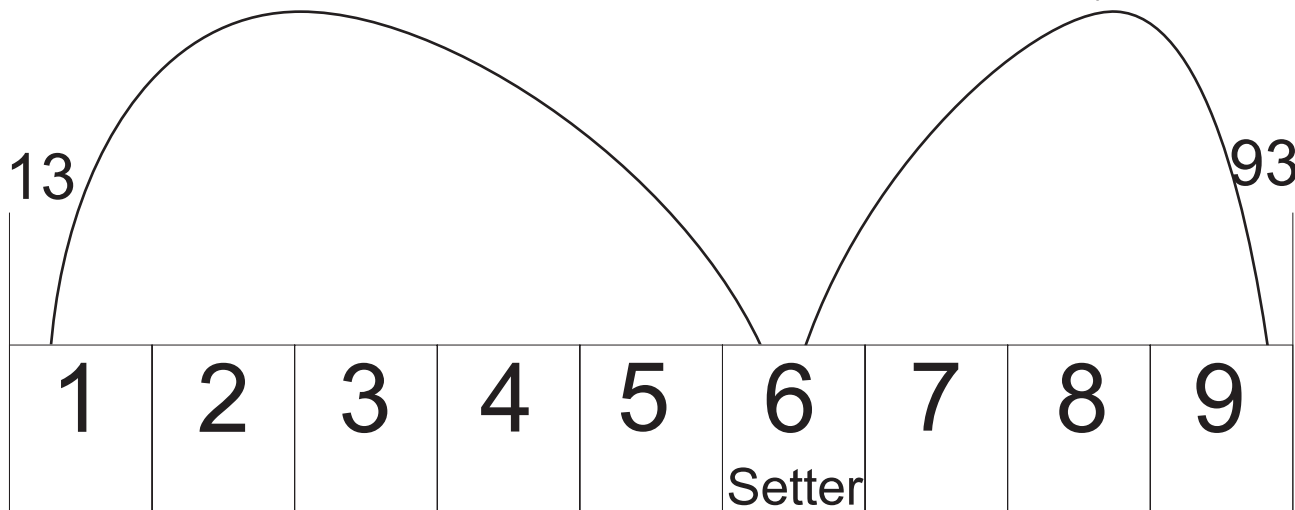

3rd Tempo 3 feet off net - 10' above the top of the net.
 approach timing is to start approach at the top of the balls flight.

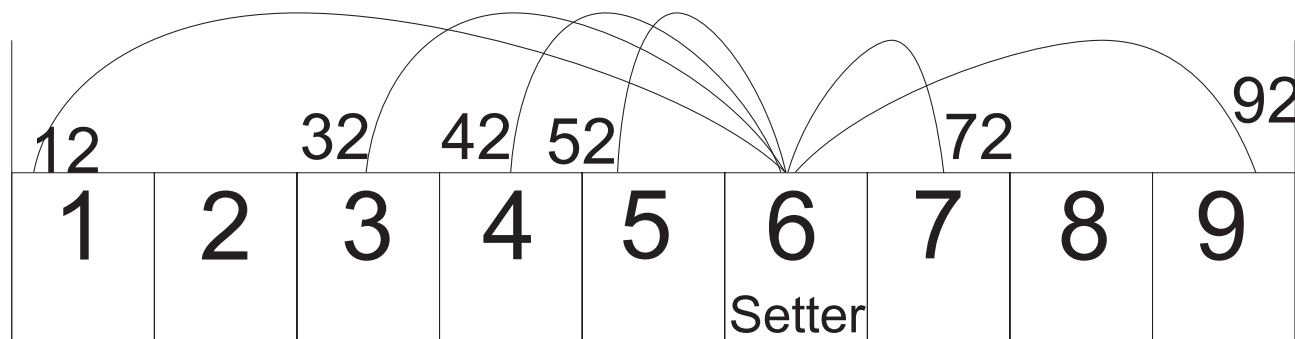

2nd Tempo 2 feet off net, Set to top of antenna height.
 Approach timing is to start approach as setter gets the ball.
 32 and 12 will start approach slightly later.

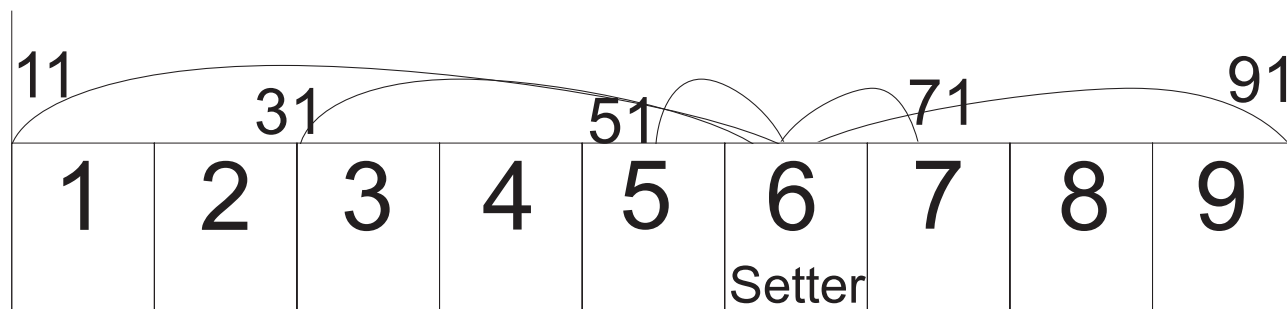

1st Tempo 1 feet off net, 1 to 2 feet high depending on jump touch of attacker
 Approach timing is to start jump as setter gets the ball.
 31 and 11 will start approach slightly later.

Back Row Attack

A B C D E

Play 1

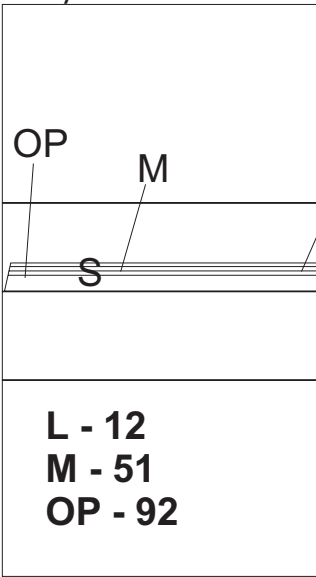

Play 2

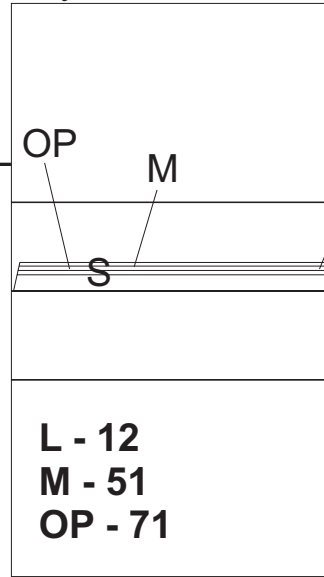

Play 3

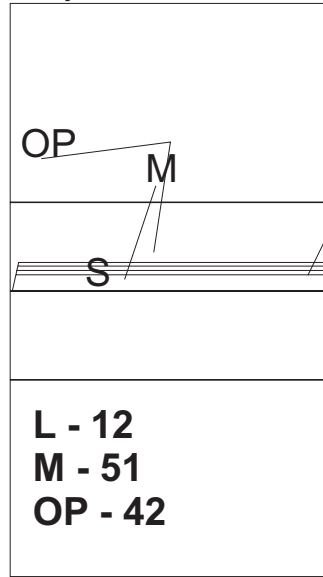

Play 4

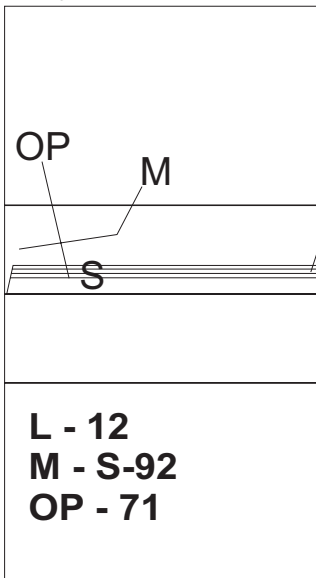

Play 5

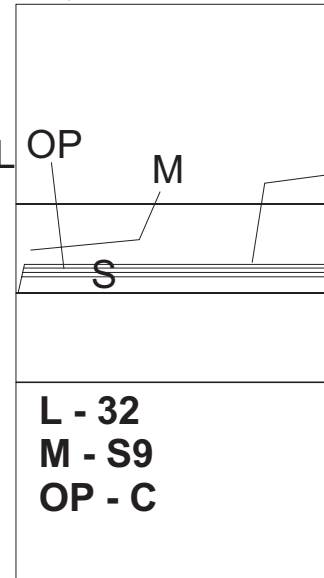

Play 6

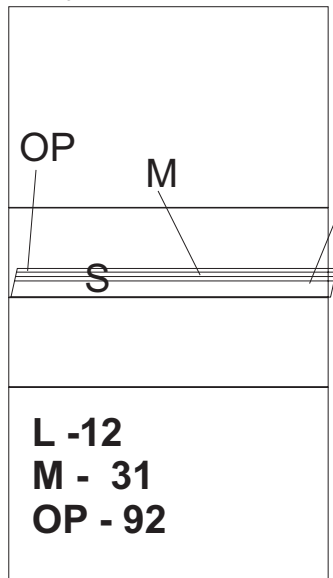

Play 7

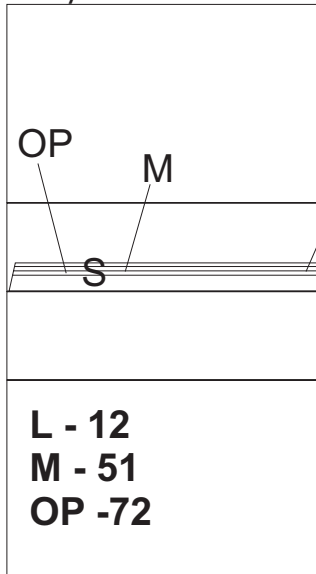

Play 8

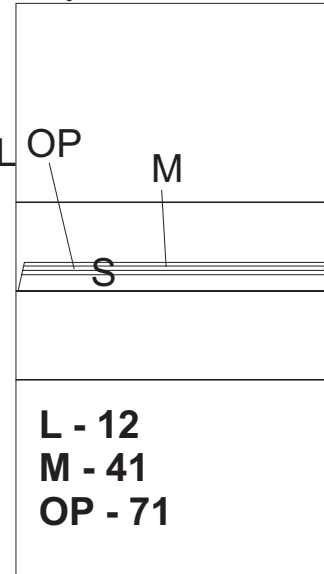

Play 9

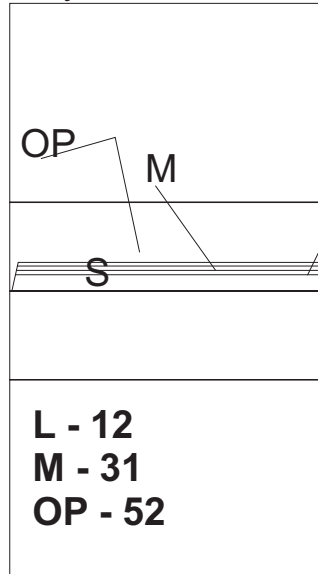

Blocking Base

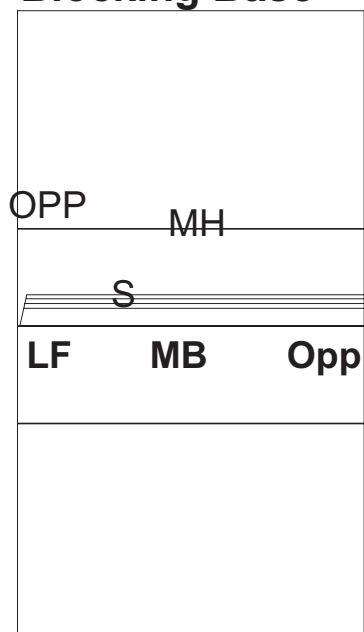

Wide Base

Used when opponents run fast attack to the antennas

Outside blocker start arms length from the antenna

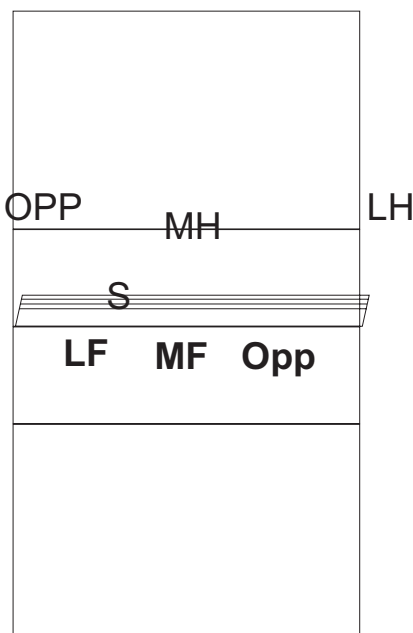

Pinch Base

Used to stop 1st tempo to middle of court

Outside blockers start 8 to 10 feet from antenna

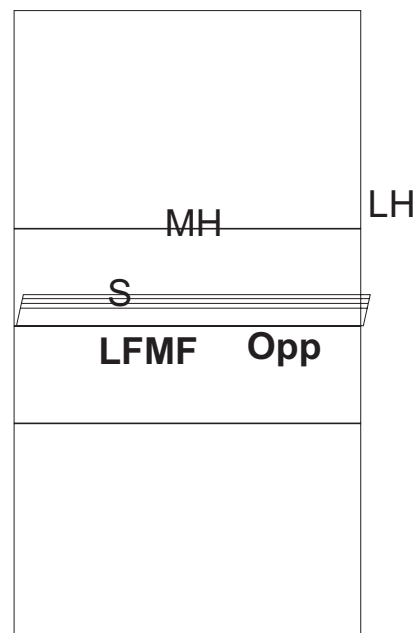

Fronting the Setter

Used with a front row setter to stop the setter attack and to help with the middle attack.

Left front blocker starts directly in front of the opposing setter

Backrow Base

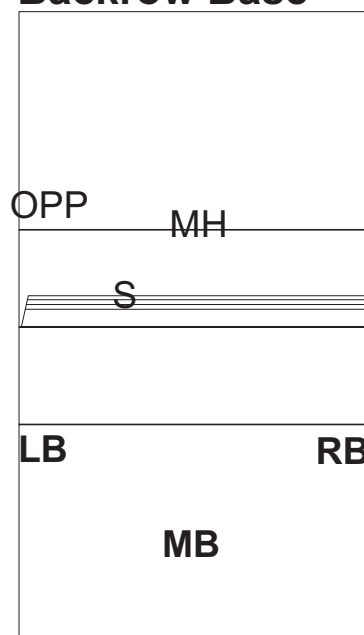

Wide base

Used with teams with good reading skills and quick players. Strength allows players to move in one direction. Weakness: Players are a long way from the zone 3 tips
Wings 12' from net, 1 foot off side line
MB 10' from end line, middle of the court.

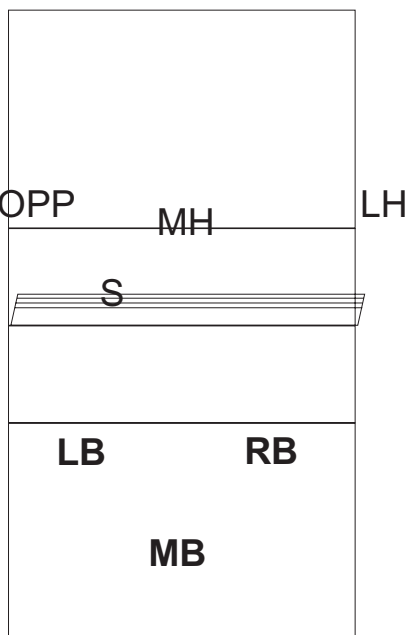

Narrow base

Used vs teams who setter tip to the middle of the court. Strength defends zone 3 better. Weakness: players have a tougher move to the line for defense.
Wings 6 or 7' off side line, 12' from net.
MB 6 or 7' from end line middle of the court

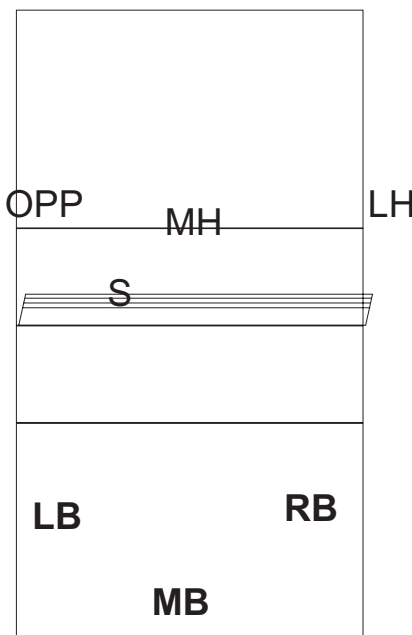

Deep base

Used to allow less movement to read positions. Strength allows better defense vs quick attack. Weakness: Require excellent reading skills or off blockers must get short setter tips.
Wings 3 or 4' off side line, 15' off net
MB 2 or 3' off end line, centered.

Middle Defense

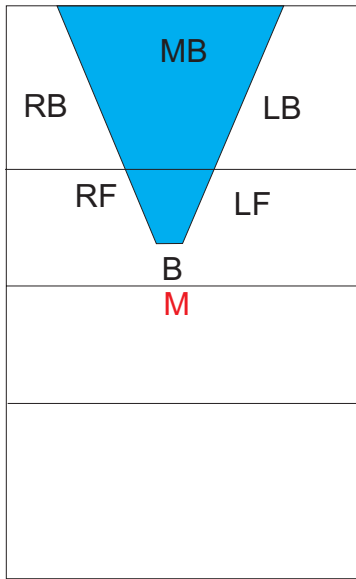

Standard Middle Defense

Single Block

Non Blocking Front row player peel off net behind block to cover for tips

Short Back row players pull back to see ball inside of block.

Middle back player covers balls hit high off block and tips deep into the court.

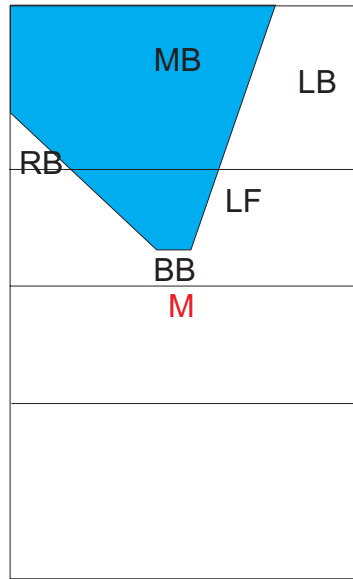

Double Block Middle Defense

Two Blockers

Extra blocker to be determined before hand.

Non Blocking Front row player peel off net behind block to cover for tips

Short Back row players behind second blocker comes around 13 ft in court to cover balls off top of block and deeper tips.

Short Back row player not behind blocker pulls back until player can see ball just outside of the block.

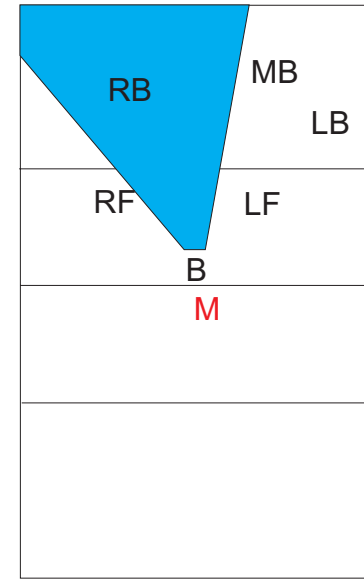

Stack Middle defense

Used with either 1 or 2 blockers.

Blocker or Blockers block set side of the court and middle back player moves into the unblocked corner of the court.

Others cover normally.

Perimeter Defense - Line digger tip cover

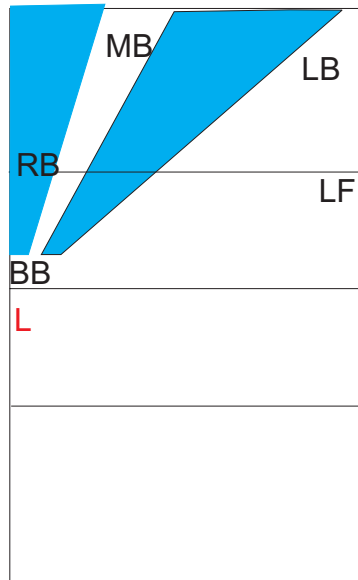

Left side attack defense.
Blocker should take away either the hitters favorite shot or allow the hitter to hit to the best defender

The Left Front Player is to defend hard cross attack

The middle back player first responsibility is to cover the seam of the block. If block is closed then the Middle player should read the hitter and adjust to the best position on the end line to cover. MB is totally responsible for the whole back line.

The Right back player is responsible for all tips.

Left Back is responsible for the deep cross court hit outside the block. The LB should be able to see the ball just inside of the block.

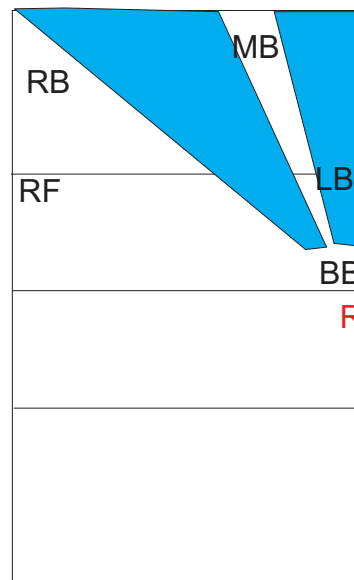

Right side attack defense.

Blocker should take away either the hitters favorite shot or allow the hitter to hit to the best defender

The Right Front Player is to defend hard cross attack.

The middle back player first responsibility is to cover the seam of the block. If block is closed then the Middle player should read the hitter and adjust to the best position on the end line to cover. MB is totally responsible for the whole back line.

The Left back player is responsible for all tips

Right Back is responsible for the deep cross court shot hit just outside the block.



In a perimeter defense you must be able to read and react to the offense. The defensive players need to make good judgements on what is happening and adjust to stop the play.

Put your best read and reactor in MB and your best pure digger in LB

Perimeter Defense - off block tip cover

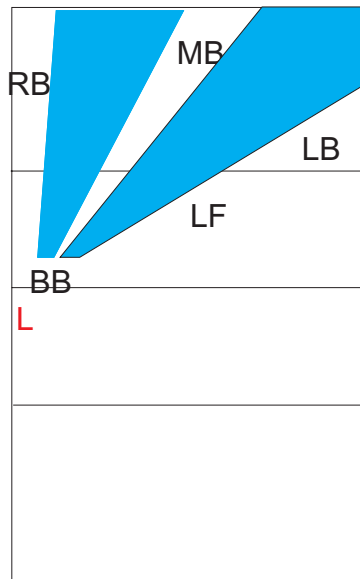

Left side attack defense.
Blocker should take away either the hitters favorite shot or allow the hitter to hit to the best defender

The Left Front Player is to cover all tips.

The middle back player first responsibility is to cover the seam of the block. If block is closed then the Middle player should read the hitter and adjust to the best position on the end line to cover. MB is totally responsible for the whole back line.

The Right back player is responsible for line hits and all tips coming straight over the block.

Left Back is responsible for the cross court hit outside the block. The LBF should be able to see the ball just inside of the block.

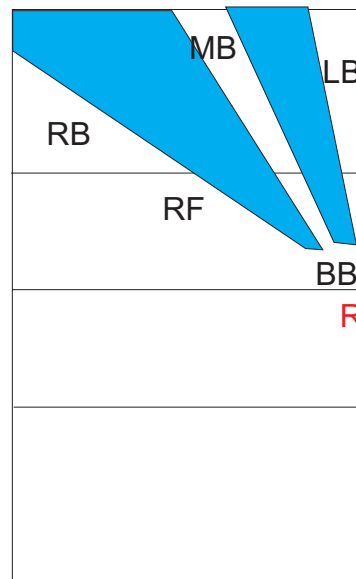

Right side attack defense.

Blocker should take away either the hitters favorite shot or allow the hitter to hit to the best defender

The Right Front Player is to cover all tips.

The middle back player first responsibility is to cover the seam of the block. If block is closed then the Middle player should read the hitter and adjust to the best position on the end line to cover. MB is totally responsible for the whole back line.

The Left back player is responsible for line hits and all tips coming straight over the block.

Right Back is responsible for the cross court hit outside the block. The RB should be able to see the ball just inside of the block.



In a perimeter defense you must be able to read and react to the offense. The defensive players need to make good judgements on what is happening and adjust to stop the play.

Put your best read and reactor in MB and your best pure digger in LB

Rotations

| | | |
|---|---|---|
| 1 | 2 | 3 |
| | | |
| 6 | 5 | 4 |
| | | |
| | | |

| | | |
|----|----|-----|
| S | M1 | O2 |
| | | |
| O1 | M2 | OPP |
| | | |
| | | |

Learning how the rotations are named and organized is important to simplify communication and to understand how offensive and defensive match ups work. Each rotation is assigned a number based on where the setter in a 5:1 system would be in service order. The numbers begin in right back and follow in a clockwise direction ending in right front.

Line up Organization

We will utilize a line up in which an outside hitter will follow the setter in service order. Each position is also designated a number based on their proximity to the setter in rotation. The Middle hitter and outside hitter which are adjacent to the setter are given a 1 following their position and the middle and outside hitter which are not adjacent to the setter are given a "2".

Rotation 1

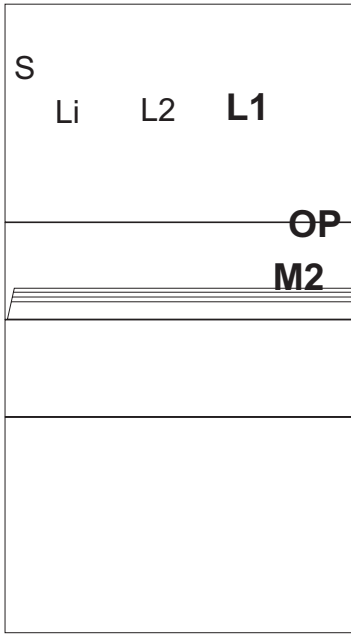

Starting Rotation

| | | |
|----|----|----|
| S | Li | L2 |
| L1 | M2 | OP |

Net

Rotation 2

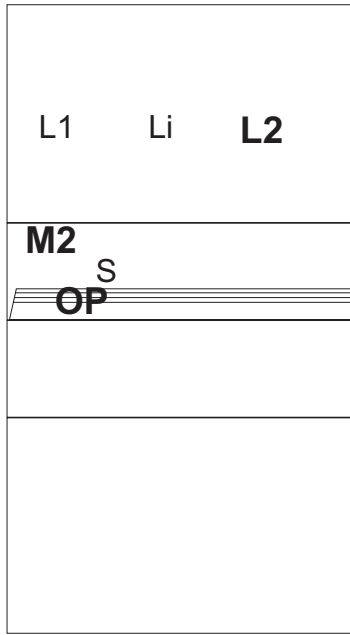

Starting Rotation

| | | |
|----|----|----|
| L1 | S | Li |
| M2 | OP | L2 |

Net

Rotation 3

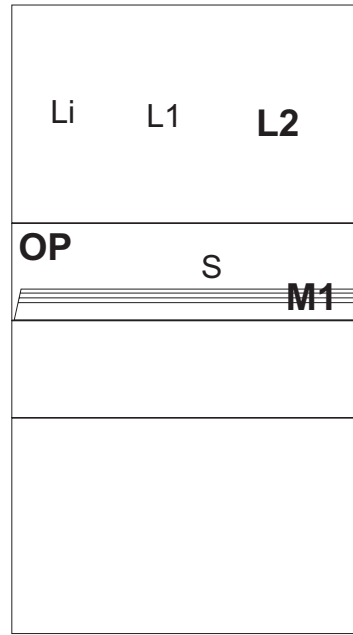

Starting Rotation

| | | |
|----|----|----|
| Li | L1 | S |
| OP | L2 | M1 |

Net

Rotation 4

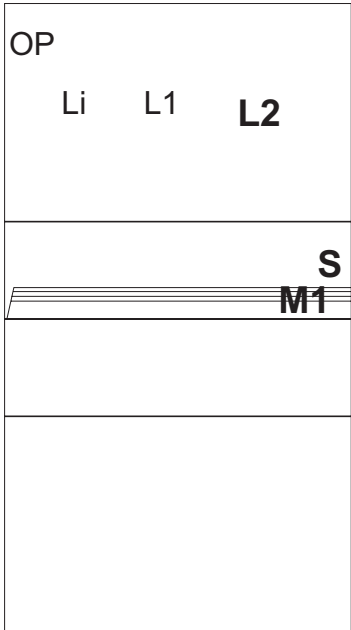

Starting Rotation

| | | |
|----|----|----|
| OP | Li | L1 |
| L2 | M1 | S |

Net

Rotation 5

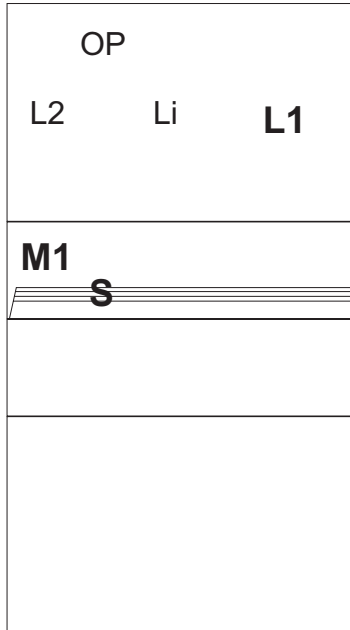

Starting Rotation

| | | |
|----|----|----|
| L2 | OP | Li |
| M1 | S | L1 |

Net

Rotation 6

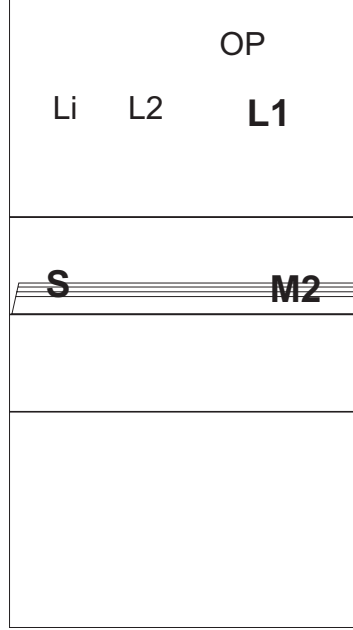

Starting Rotation

| | | |
|----|----|----|
| Li | L2 | OP |
| S | L1 | M2 |

Net

Serve Receive 5-1 Oprion 1

Rotation 1

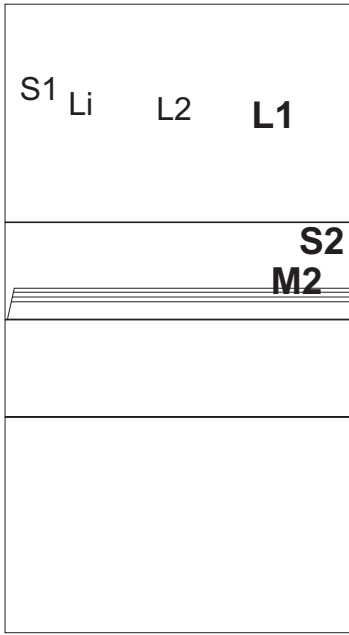

Starting Rotation

| | | |
|----|----|----|
| S1 | Li | L2 |
| L1 | M2 | S2 |

Net

Rotation 2

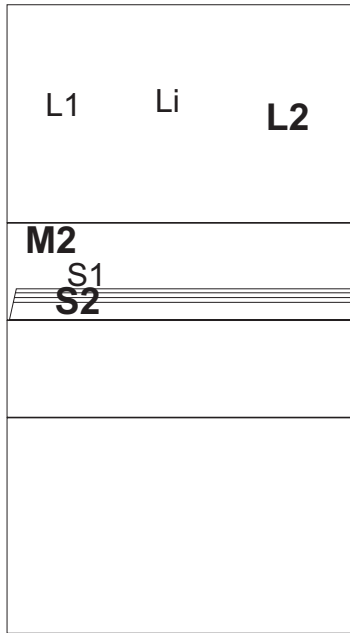

Starting Rotation

| | | |
|----|----|----|
| L1 | S1 | Li |
| M2 | S2 | L2 |

Net

Rotation 3

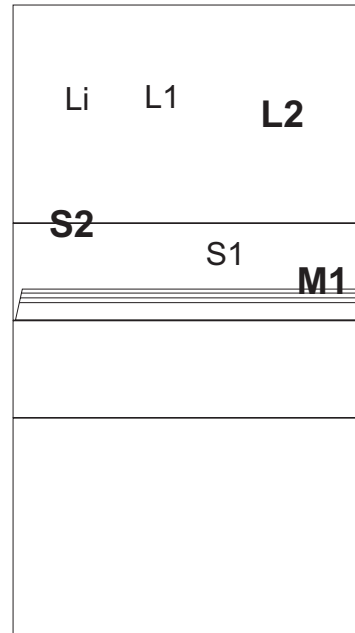

Starting Rotation

| | | |
|----|----|----|
| Li | L1 | S1 |
| S2 | L2 | M1 |

Net

Rotation 4

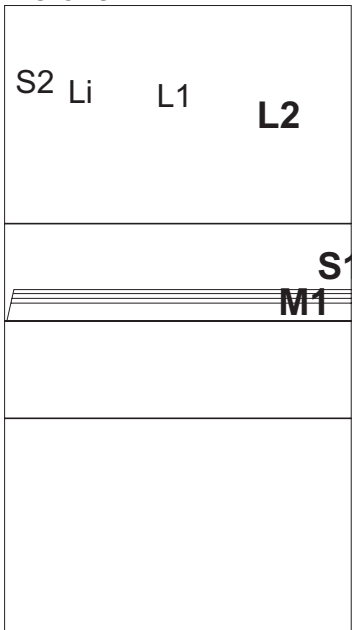

Starting Rotation

| | | |
|----|----|----|
| S2 | Li | L1 |
| L2 | M1 | S1 |

Net

Rotation 5

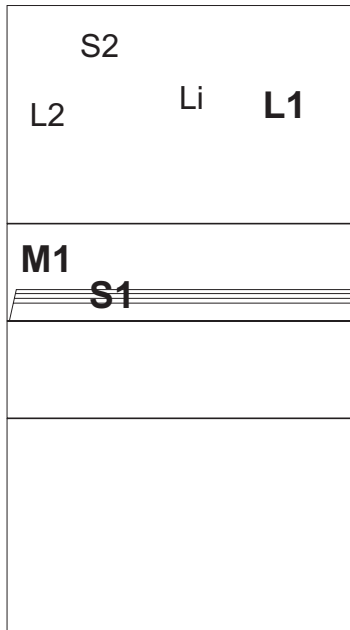

Starting Rotation

| | | |
|----|----|----|
| L2 | S2 | Li |
| M1 | S1 | L1 |

Net

Rotation 6

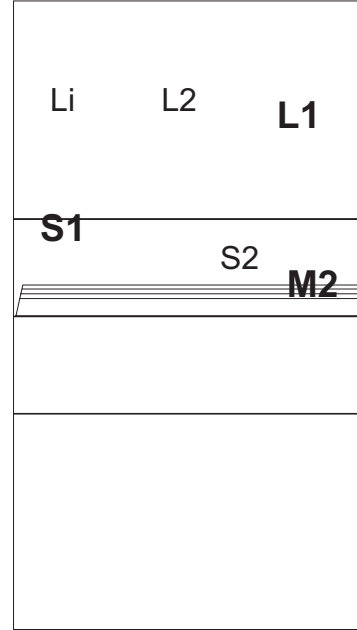

Starting Rotation

| | | |
|----|----|----|
| Li | L2 | S2 |
| S1 | L1 | M2 |

Net

Serve Receive 6-2 Oprion 1

Serving Zones

